



Product Announcement

NEAPCO's Exclusive Sprinter Fix

Updated to include through model year 2009!

*NEAPCO® is proud to announce the availability of two new driveshaft repair kits for Dodge, Freightliner, and Mercedes-Benz Sprinter vans through year models **2009** that are configured with two piece or three piece driveshafts. These kits, along with standard NEAPCO off the shelf components, allow the driveline specialist to convert a staked in place OEM universal joint driveshaft to conventional 1350 series.*

*The **N135-254 fixed center section driveshaft repair kit** includes a center support bearing and will replace the OEM flange and flange yoke with a conventional mid-ship stub and end yoke.*

*The **N135-254-1 slip center section driveshaft repair kit** includes a center support bearing and will replace the OEM slip sleeve and yoke shaft with a conventional slip mid-ship stub and slip yoke.*

Both kits are configured for use with standard 3"X.083" tubing. However, the components can be modified to work with the OEM tubing for added flexibility.

NEAPCO Components, LLC 740 Queen St. Pottstown, PA 19464

Phone: 800-821-2374

E-mail: hd@neapco.com

©2009 NEAPCO Components, LLC

Innovative Drivetrain Solutions™

9901138

Fax: 610-326-2002

Web site: www.neapco.com

10/2011

1



N135-254 FIXED CENTER SECTION DRIVESHAFT REPAIR KIT



*This kit contains a newly developed half round style end yoke that is designed specifically for the **fixed center section driveshaft repair**. By including a special bushing, the end yoke can be used with a standard Neapco mid-ship stub which provides added flexibility.*

For your convenience, the kit also includes the correct mid-ship nut and center support which can also be purchased separately.



N135-254-1 SLIP CENTER SECTION DRIVESHAFT REPAIR KIT



*This kit contains a newly developed slip mid-ship stub that is designed specifically for the **slip center section driveshaft repair**. The precision ground bearing diameter is designed to fit into the center support bearing.*

For your convenience and added flexibility, the kit also includes the correct Neapco slip yoke / seal and center support which can also be purchased separately.



SPRINTER DRIVESHAFT REPAIR COMPONENTS

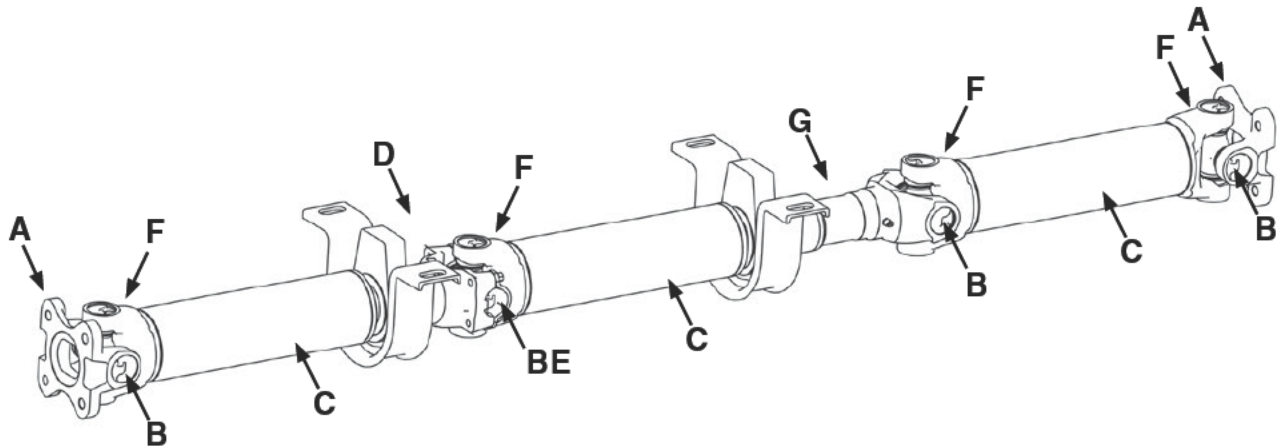

KEY	PART NUMBER	PART DESCRIPTION	QTY 3-PC SHAFT	QTY 2-PC SHAFT
A	N3-2-5104 (04-06)	Flange Yoke	2	2
	N3-2-5107 (07-09)			
B	2-0799	Universal Joint	4	3
C	N24-30-42-72	Tubing	3	2
D	N135-254	Repair Kit	1	0
E	1-0019	Strap Kit	1	0
F	N3-28-57	Tube Weld Yoke	4	3
G	N135-254-1	Repair Kit	1	1